



# Sustainable Innovation in Welding Technology: A Low-Cost Portable Arc Welder from Recycled E-Waste

Ogunwusi Adebimpe Abosede<sup>1</sup>, Ben-Festus Blessing Nneka<sup>1</sup>, Ben Festus<sup>1,2</sup>

<sup>1</sup> Department of Physics, Federal Polytechnic Ede, Osun State, Nigeria

<sup>2</sup> Department of Metallurgy, University of Johannesburg, Johannesburg, South Africa

Received: 20 August 2025 | Accepted: 04 November 2025 | Published: 10 January 2026

Corresponding author: abosede20162016@gmail.com | A.A. Ogunwusi

## Abstract

The rising demand for affordable welding solutions in developing regions, alongside the environmental challenge of electronic waste (e-waste), has motivated the design of a low-cost arc welder fabricated from recycled components. This study presents the development and performance evaluation of a portable arc welding machine constructed from repurposed microwave oven transformers (MOTs). Two MOTs rated at 1080 W each were rewound to deliver a combined secondary output of 40.3 V and an average current of 125 A, suitable for welding mild steel rods of up to 5 mm thickness. A 4000 W dimmer circuit enabled smooth current regulation and arc stability during operation, while integrated 12 V DC cooling fans maintained safe thermal conditions. The prototype achieved a transformer efficiency of 78.5%, demonstrating steady arc performance and satisfactory weld penetration comparable to commercial welders in the 120–150 A class. By utilizing e-waste components and maintaining reliable welding capability, this work provides a sustainable and technically viable pathway toward low-cost welding technology in resource-constrained settings.

**Keywords:** E-waste, electric welding machine, environmental pollution, recycling, dimmer, microwave oven

## 1. Introduction

Electronic waste, commonly known as e-waste, encompasses discarded electronic and electrical components that have been released into the environment (Shahabuddin et al., 2023). This category includes a wide range of items such as household and consumer electronics (e.g., microwave ovens, refrigerators, washing machines, televisions), information communication technology (ICT) and telecommunication devices, medical equipment, industrial electronic machinery, mobile phones, tablets, and computer systems (Huang, 2014; D. S. V Prasad et al., 2009). Notably, these e-waste materials are primarily non-biodegradable and pose a significant threat to the environment (Bimir, 2020; Lebbie et al., 2021). In 2021, the global generation of e-waste reached an alarming 57.4 million metric tons, of which only about 17.4% were recycled (Forti et al., 2020). The remainder often ends up in incinerators, landfills, or is exported to developing nations such as Nigeria, where informal recycling is prevalent (Adeobu et al., 2023; Maes & Preston-Whyte, 2022; Nnorom & Odeyingbo, 2020). Despite initiatives such as the E-waste Producer Responsibility Organization of Nigeria (EPRON) launched in 2018 (Faluyi, 2020), poor enforcement and limited recycling infrastructure continue to hinder sustainable e-waste management in the region.

While e-waste has traditionally been viewed as a disposal problem, recent studies emphasize its potential as a source of reusable components for low-cost fabrication and innovation (Shahabuddin et al., 2023; Van Yken et al., 2021). One such application involves repurposing transformers from discarded microwave ovens, known as microwave oven transformers (MOTs), which possess high current-handling capability and robust construction suitable for welding and power conversion applications (Alansari & Albannai, 2020; Sandoval & Mendoza-Araya, 2016). However, earlier MOT-based designs often exhibited limited control over current flow, thermal instability, and inefficient cooling, restricting their continuous use for arc welding operations.

Electric welding machines enable the melting and fusion of metal parts by utilizing heat generated through the flow of electrical current (Moreira et al., 2018). These machines rely on step-down transformers to significantly reduce the incoming voltage, enabling the passage of a high current. However, conventional electric welding systems are typically characterized by low power factors, harmonic distortions, and current imbalances (IEEE, 2015; Junior et al., 2015). Such problems can lead to voltage flicker and reduced power quality in distribution networks (Das, 2015). The present study addresses these challenges by integrating a dimmer-based current regulation system and dual cooling fans, ensuring smoother current transitions and better heat management. This design reduces the abrupt current surges responsible for harmonic generation, thereby improving the power stability of the system.

Several studies have explored techniques for optimizing electric welding performance and reducing grid disturbances (Ingle et al., 2023; Moreira et al., 2018; Rohith et al., 2018; Sathish et al., 2019; Vaidya et al., 2025). For example, Moreira et al., (2018) developed computational models for TIG and MIG welding machines, aiding the study of power quality, compensation, and connection requirements for special loads in the electric network. Rohith et al., (2018) focused on the design and analysis of a portable friction stir welding machine for low-power consumption, using simulation tools without physical implementation. Sandoval & Mendoza-Araya, (2016) examined the impacts of using MOTs on micropower grids, demonstrating that modification of MOTs could improve performance, and suggests that by modifying the MOTs, the behaviour of the transformer can be greatly enhanced for positive outcomes. Alansari & Albannai, (2020) recycled MOTs to build an arc welding setup, but the absence of a voltage control mechanism and poor cooling led to reduced efficiency and thermal stress..

These reviews collectively highlight a clear research gap in the development of MOT-based welding systems that are not only low-cost and portable but also stable, controllable, and thermally efficient. To bridge this gap, the present work fabricates a sustainable and technically enhanced arc welding machine utilizing recycled MOTs coupled with a 4000 W dimmer circuit for current control and active cooling fans to dissipate heat during extended use. The study therefore contributes both environmentally and technically by demonstrating how e-waste components can be re-engineered into a functional welding system that balances sustainability, performance stability, and affordability.

## 2. Methodology

### 2.1 Principle of operation

Fig. 1 shows the functional block diagram that governs the operational principles of the electric welding machine constructed in this study. This welding machine harnesses the capabilities of two transformers repurposed from discarded microwave oven units. To facilitate a higher output current, these transformers are connected in series and powered by a 220 V alternating current (AC) supply through a 4000 W dimmer circuit constructed using BT136 power transistors. The welding probes are linked to the output terminals of the transformers for welding purposes. The dimmer unit allows the user to fine-tune the current output from the recycled transformers, thereby controlling the heat intensity of the low-cost electric welding machine. Being a heat-generating unit and to ensure optimal performance of the fabricated device, two direct current (DC) heat extraction fans are integrated into the setup. These fans are powered by a regulated 12 VDC voltage source to maintain the appropriate operating temperature.

Fig 1. Block diagram of the fabricated electric arc welding machine

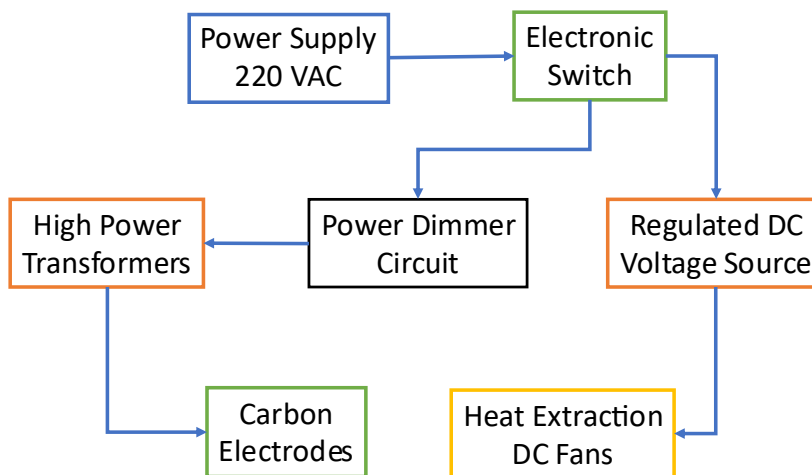

## 2.2 Transformer Winding

Two high-power transformers were salvaged from discarded microwave ovens and repurposed for use in this study. The selection of a microwave oven transformer was motivated by the durable materials used in its construction and its capacity to withstand high temperatures while maintaining a stable current flow. Typically, a microwave oven transformer generates a high voltage that is unsuitable for welding applications. Consequently, modifications were necessary to adapt the transformer for electric welding as suggested by Sandoval and Mendoza-Araya (2016). The copper coils within the secondary winding section of the microwave oven transformers were skillfully removed using a hacksaw, ensuring that the primary winding coils remained undamaged (refer to Fig. 2). Subsequently, 26 turns of insulated silicon cables of 4 mm gauge were meticulously wound around the secondary sections of the two MOTs as shown in Fig. 3.

**Fig 2.** Recycled MOT with secondary winding hacked off



**Fig 3.** Repurposed MOTs with new secondary windings

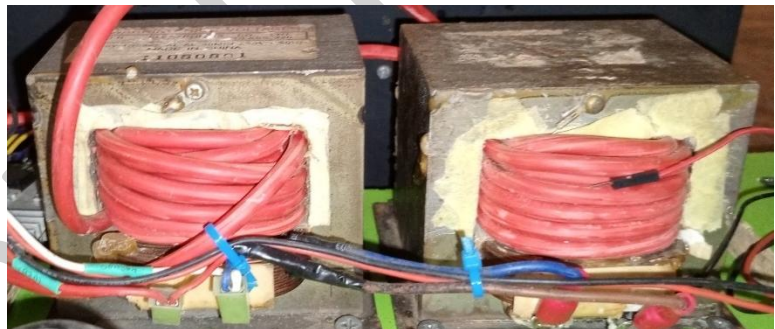

To determine the volt-ampere (VA) that the transformer can provide, the cross-sectional area of the transformer core was determined experimentally. The constant C was taken as 1 since the microwave oven transformer is an intermittent-use transformer type. The volt-ampere was then determined using:

$$VA = \left( \frac{\text{Core area (sq. cm)}}{C} \right)^2 = \left( \frac{\text{Core area (sq. cm)}}{1.03} \right)^2 \tag{1}$$

After winding of the secondary section, the transformer efficiency ( $\eta$ ) was determined as ratio of the output power to the input power given by the following equation (Electrical4U, 2020):

$$\text{Efficiency, } \eta = \frac{\text{Output Power}}{\text{Input Power}} \times 100\% = \frac{\text{Output Power}}{\text{Output Power} + \text{losses}} \times 100\% \tag{2}$$

The winding parameter for the secondary section was estimated using the voltage across the winding (V in volts r.m.s), the form factor of the AC waveform (F), the frequency in Hz (f), the cross-sectional area of the core (a), the number of turns on the considered winding (N), and the flux density in maxwells per unit area (B). The winding equation is thus given by:

$$V = 4FfaNB \times 10^{-8} \tag{3}$$

### 3. Results and Discussions

Figs. 4 and 5 show the complete setup of the electric welding machine that was constructed in this research. The device operates efficiently when connected to a 220 VAC power supply. The combined output voltage from the secondary section of the recycled MOTs used in this study was 40.3 VAC as measured by a digital multimeter, while the measured average current output was 125 A under full load conditions. The low secondary voltage relative to the primary input indicates that the transformers functioned effectively in a step-down configuration suitable for arc welding. As observed by Alansari & Albannai, (2020), connecting two MOTs in series increases the effective current draw from the power source, leading to higher welding currents compared to a single MOT setup. The dimmer circuit provided fine control of current delivery between 60 A and 125 A, enabling flexible operation with electrodes up to 4.0 mm in diameter.

**Fig 4.** Cross-section of the internal parts of the fabricated electric welding machine

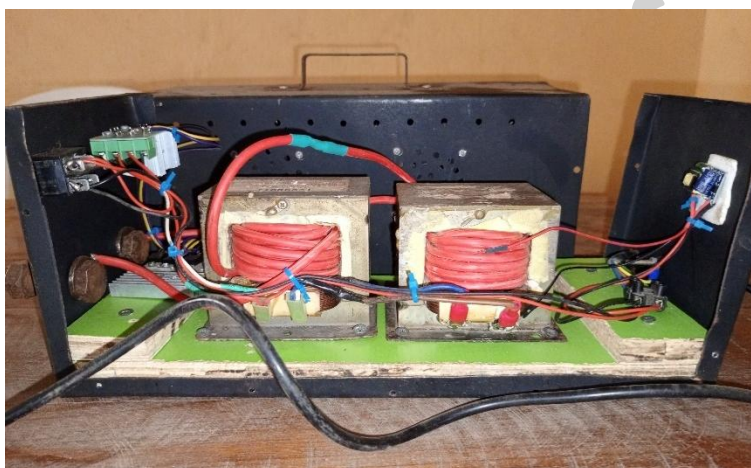

**Fig 4.** Complete setup of the electric welding machine fabricated in this study



### 3.1 Transformer efficiency and performance evaluation

The overall output efficiency of the transformer, computed using equation (2), was determined to be 78.5%. Table 1 summarizes the input and output electrical parameters obtained during the test.

**Table 1.** Transformer performance parameters

Parameter	Measured value
Input voltage ( $V_{in}$ )	220 V
Input current ( $I_{in}$ )	7.2 A
Input power ( $P_{in}$ )	1584 W
Output voltage ( $V_{out}$ )	40.3 V
Output current ( $I_{out}$ )	5.0 A
Output power ( $P_{out}$ )	1248 W
Efficiency ( $\eta$ )	78.5%

The calculated efficiency agrees with typical performance ranges for rewound MOT-based welders (70–80%) reported by (Sirait et al., 2020), confirming the functional viability of the recycled design.

### 3.2 Transformer loss estimation

The fabricated welder was evaluated against a 140 A commercial arc welder of equivalent category. Comparative parameters are presented in Table 2.

**Table 2.** Performance comparison with a commercial arc welding unit

Feature	Fabricated MOT welder	Commercial arc welder
Output voltage (V)	40.3	42.0
Output current (A)	60 – 125	60 – 140
Efficiency (%)	78.5	82 – 85
Maximum electrode size (mm)	4.0	4.0
Duty cycle @ 100 A	55%	60%
Cooling type	Dual 12 V DC Fans	Forced Air Fan
Arc stability	Stable	Stable
Weld penetration	Good (3.5 mm mild steel)	Good (up to 6 mm)

Although slightly lower in efficiency, the fabricated prototype demonstrated comparable arc stability and weld penetration for mild steel rods of 3–5 mm thickness. The current regulation via dimmer allowed a smooth transition between low and high heat conditions without excessive flicker or spatter.

Furthermore, the fabricated MOT welding machine was utilized to create joints in different metals. When compared with the joints made with commercial welding machines, good joint features were observed. Compared to the MOT-based arc welding unit by Alansari & Albannai (2020), which suffered from poor efficiency, possibly due to the parallel MOT connection adopted as opposed to the series MOT connection adopted in this study, the present design achieved improved current control and better thermal management through the integration of dimming and cooling.

### 3.3 Environmental and sustainability considerations

While this study underscores the environmental value of repurposing discarded microwave transformers, it is recognized that the system still consumes substantial electrical energy during welding. Hence, the sustainability benefit primarily lies in waste reduction and material reuse, not in operational energy savings. Future work could explore integrating power-factor correction circuits or energy recovery modules to minimize electrical consumption. Nonetheless, using recycled components reduces landfill contributions and the environmental footprint associated with new material production.

## 4. Conclusion

This study successfully developed a low-cost portable arc electric welding machine fabricated from recycled microwave oven transformers. The prototype achieved a measured transformer efficiency of 78.5% and effectively

welded mild steel rods and sheets up to 5 mm thickness, demonstrating practical suitability for small-scale fabrication and repair work. The novelty of the design lies in the series connection of two MOTs combined with a 4000 W dimmer circuit, which provided controllable welding current between 60 A and 125 A and ensured stable arc performance across different operating loads. When benchmarked against a commercial 140 A welding unit, the fabricated device exhibited comparable arc stability, electrode compatibility (up to 4 mm), and weld penetration quality, validating its technical effectiveness despite lower efficiency.

The use of recycled e-waste in the fabrication of the electric welding machine is a sustainable and eco-friendly innovation that reduces the environmental impact of welding processes. The study demonstrates the potential of using recycled materials to create low-cost and effective welding machines that can contribute to sustainable development. However, certain limitations remain. The present prototype has not undergone durability and long-term thermal stress testing, and its load capacity and duty cycle have not yet been benchmarked against industrial standards. In addition, mechanical strength characterization of the welded joints and arc emission analysis were beyond the scope of this work.

## Declarations

**Acknowledgement:** The authors wish to acknowledge the effort of Miss Oyeleye Modupe Margaret and Miss Ajayi Esther Oluwabukola for assisting with the experimentation aspect of this research work.

**Data availability:** Data will be made available upon reasonable request.

**Funding:** This study received no funding.

**Competing interests:** The authors declare that they have no known competing or financial interests.

**Open access permissions.** Published under Creative Commons Attribution-NonCommercial-NoDerivatives 4.0 International License. Visit <http://creativecommons.org/licenses/by-nc-nd/4.0/> for more information.

## References

- Alansari, A. A., & Albannai, A. I. (2020). Recycling microwave oven transformers to build up an arc welding process. *International Journal of Scientific and Technology Research*, 9(2), 3963–3968.
- Andeobu, L., Wibowo, S., & Grandhi, S. (2023). Informal E-waste recycling practices and environmental pollution in Africa: What is the way forward? *International Journal of Hygiene and Environmental Health*, 252, 114192. <https://doi.org/https://doi.org/10.1016/j.ijheh.2023.114192>
- Bimir, M. N. (2020). Revisiting e-waste management practices in selected African countries. *J. Air Waste Manag. Assoc.*, 7(7), 659–669. <https://doi.org/10.1080/10962247.2020.1769769>
- Das, J. C. (2015). *Power system harmonics and passive filter designs* (1st ed.). Wiley.
- Electrical4U. (2020). Efficiency of Transformer. <https://www.electrical4u.com/efficiency-of-transformer/>
- Faluyi, I. (2020). Nigeria's response to the global e-waste challenge. *The Guardian*.
- Forti, V., Balde, C. P., Kuehr, R., & Bel, G. (2020). *The Global E-Waste Monitor 2020: Quantities, Flows and the Circular Economy Potential*.
- Huang, J. (2014). Leaching behavior of copper from waste printed circuit boards with Brønsted acidic ionic liquid. *Waste Management*, 34(2), 483–488.
- IEEE. (2015). Recommended practice for the analysis of fluctuating installations on power systems. *IEEE Std 1453-2015* (Revision of IEEE Std 1453-2011).
- Ingle, A. H., Gaydhane, P. M., Matey, R. K., Landge, N. K., Sarve, J. G., & Patle, M. K. (2023). A Literature Review on Fabrication of Portable Spot Welding Machine. *International Journal for Research in Applied Science and Engineering Technology*, 11(6), 1193–1197. <https://doi.org/10.22214/ijraset.2023.53844>
- Junior, A. J. P. R., Gondim, I. N., Junior, J. R. M., & Delaliba, A. C. (2015). A practical electric arc furnace model for flicker assessment. *Journal of Control, Automation and Electrical Systems*, 26(1), 68–79.
- Lamendola, M. (2000). Basics of Transformer Voltage Efficiency. <https://www.ecmweb.com/content/article/20889906/basics-of-transformer-voltage-efficiency>
- Lebbie, T. S., Moyebi, O. D., Asante, K. A., Fobil, J., Brune-Drisse, M. N., & Suk, W. A. (2021). E-waste in Africa: a serious threat to the health of children. *Health, Int. J. Environ. Res. Publ.*, 18(16), 8488.
- Maes, T., & Preston-Whyte, F. (2022). E-Waste it wisely: lessons from Africa. *SN Appl. Sci.*, 4(3), 1–12.

- Moreira, A. C., da Silva, L. C. P., & Paredes, H. K. M. (2018). Power Quality Study and Analysis of Different Arc Welding Machines. *Journal of Control, Automation and Electrical Systems*, 29(2), 163–176. <https://doi.org/10.1007/s40313-017-0363-6>
- Nnorom, I. C., & Odeyingbo, O. A. (2020). 14 - Electronic waste management practices in Nigeria (M. N. V. Prasad, M. Vithanage, & A. B. T.-H. of E. W. M. Borthakur (eds.); pp. 323–354). Butterworth-Heinemann. <https://doi.org/https://doi.org/10.1016/B978-0-12-817030-4.00014-0>
- Prasad, D. S. V, Raju, G. V. R. P., & Kumar, M. A. (2009). Utilization of industrial waste in flexible pavement construction. *Electronic Journal of Geotechnical Engineering*, 14 D(January 2009).
- Rohith, R. R., Pranesh, M. A., & Logesh, K. (2018). Design and analysis of a portable friction stir welding machine. *Materials Today: Proceedings*, 5(9), 19340–19348. <https://doi.org/10.1016/j.matpr.2018.06.293>
- Sandoval, R., & Mendoza-Araya, P. A. (2016). Impacts of using microwave oven transformers on micropower distribution grids. *GHTC 2016 - IEEE Global Humanitarian Technology Conference: Technology for the Benefit of Humanity, Conference Proceedings*, 495–501. <https://doi.org/10.1109/GHTC.2016.7857325>
- Sathish, D., Kavin, K. R., & Jeevan, E. A. (2019). Design and fabrication of portable resistance spot welding machine. SSRN. <http://dx.doi.org/10.2139/ssrn.3362697>
- Shahabuddin, M., Uddin, M. N., Chowdhury, J. I., Ahmed, S. F., Uddin, M. N., Mofijur, M., & Uddin, M. A. (2023). A review of the recent development, challenges, and opportunities of electronic waste (e-waste). *International Journal of Environmental Science and Technology*, 20(4), 4513–4520. <https://doi.org/10.1007/s13762-022-04274-w>
- Sirait, A. H., Tarigan, K., & Situmorang, M. (2020). Manufacture of High Current Low Voltage Power Supply with Using the MOT (Microwave Oven Transformer). *International Journal of Scientific Research in Science, Engineering and Technology*, 7(4), 301–306. <https://doi.org/10.32628/IJSRSET207477>
- Vaidya, S., Prasad, K., & Kilby, J. (2025). The Role of Multilevel Inverters in Mitigating Harmonics and Improving Power Quality in Renewable-Powered Smart Grids: A Comprehensive Review. In *Energies* (Vol. 18, Issue 8). <https://doi.org/10.3390/en18082065>
- Van Yken, J., Boxall, N. J., Cheng, K. Y., Nikoloski, A. N., Moheimani, N. R., & Kaksonen, A. H. (2021). E-Waste Recycling and Resource Recovery: A Review on Technologies, Barriers and Enablers with a Focus on Oceania. In *Metals* (Vol. 11, Issue 8). <https://doi.org/10.3390/met11081313>

**Publisher Disclaimer.** React Journal and its affiliates remain neutral with respect to institutional affiliations, jurisdictional claims in published maps, and author declarations. The views and opinions expressed in all published articles are solely those of the authors and do not necessarily reflect the official policy or position of REACT Journal, its editorial board, or the Federal Polytechnic Ede.